

### Warranty

CDI warrants solely to the buyer that the Model 5400 Flowmeter shall be free from defects in materials and workmanship, when given normal, proper and intended usage, for three years from the date of purchase. During the warranty period, CDI will repair or replace (at its option) any defective product at no cost to the buyer. The foregoing warranty is in lieu of any other warranty, express or implied, written or oral (including any warranty of merchantability or fitness for a particular purpose). CDI's liability arising out of the manufacture, sale or supplying of the flowmeter, whether based on warranty, contract, tort or otherwise, shall not exceed the actual purchase price paid by the buyer, and in no event shall CDI be liable to anyone for special, incidental or consequential damages.

**cdimeters**

CDI Meters, Inc.

email: [support@cdimeters.com](mailto:support@cdimeters.com)

call toll free: 866-885-2462

[www.cdimeters.com](http://www.cdimeters.com)

# CDI 5400 Flowmeter

## Installation and Operating Instructions

### Application

The meter may be used with either compressed air or Nitrogen, at pressures from atmospheric to 200 psig. The air or Nitrogen must be free of oil and suspended water droplets. Refer to the data sheet for the calibrated range of the particular meter. The meter will continue to read at much higher flow rates, but there may be significant inaccuracy

### Location

The meter must not be installed in a hazardous location. If it must be installed where it could be exposed to moisture, consult CDI about weather-resistant modifications. For best accuracy, the meter should be installed with at least 30 diameters of straight pipe upstream and five diameters downstream. Avoid installing the meter downstream of any item that could distort or concentrate the flow, such as a partially-closed valve, a regulator, a filter or moisture separator, two closely-spaced elbows in different planes, a long-radius elbow, an increase in pipe size or a curved hose. Allow at least 50 diameters of straight pipe between any such item and the meter. If the meter will be directly downstream of a standard elbow or a tee with at least ten diameters of straight pipe upstream of it, 20 diameters of straight pipe upstream of the meter is acceptable. Select a location that meets these requirements and also provides good visibility from the plant floor.

### Preparing the Holes

When the holes are drilled, metal shavings will enter the pipe. Make sure that filters or other provisions are present downstream to prevent the shavings from damaging equipment or product or being blown out and causing injury.

Shut down the air and make sure that it will remain shut off while the meter is being installed. Before starting to drill the holes, make sure that the air pressure is completely bled down. For the larger size meters, the drill guide is a half ring with two drill bushings mounted in it. Secure this half ring in place by bolting it to the back half ring that came with the meter. For the smaller meters, the drill guide is an aluminum block with two drill bushings. Secure this block to the pipe with a C clamp, hose clamp or a chain clamp. When using the small drill guide, check the probe arrangement of the meter against the hole pattern you are drilling. Drill

the holes, remove the drill guide, and remove any burrs that were formed when you drilled the holes.

## Installing the Meter

Make sure the probes are clean. If there is any oil or dirt on them, clean them with alcohol or a similar degreaser. If the housing must be rotated to suit the installation, loosen (do not remove) the two small cap screws in the plate beneath the housing, rotate the housing, keeping it centered, and tighten the screws. Insert the probes into the holes in the pipe, with the flow arrow pointing in the direction of flow. Tighten the screws carefully, alternating screws, so that the two sides of the collar are pulled together evenly. If the LED display is upside down, remove the cover of the meter, rotate it and the display panel 180 degrees, and reinstall the cover. If the yellow caution label is not visible, apply the extra caution label from the bag of parts in a visible location.

## Wiring the Meter

### POWER

Either use the 18-Volt dc wall-plug supply provided with the meter, or connect an 18- to 24-Volt dc supply to the supply- and supply+ terminals.

### REMOTE DISPLAY

If you are using Summing Remote Display, connect the DC-, DC+ and display terminals in the meter to the corresponding terminals in the display. The meter may be powered from the remote display if the connecting cable is 22 gauge or larger and the distance is no greater than 60 feet.

### MILLIAMP OUTPUT

The mA- and mA+ terminals are optically isolated from the remainder of the circuit and may be wired as part of an externally-powered loop. When this is done, the jumper that is supplied with the meter must be removed. If you use an external supply, be sure that it has sufficient voltage to overcome an 8.2 Volt drop within the meter in addition to any other voltage drops in the loop.

Alternatively, the meter's supply may be used to power the milliamp signal. Leave the jumper in place from the supply+ terminal to mA+. Wire from

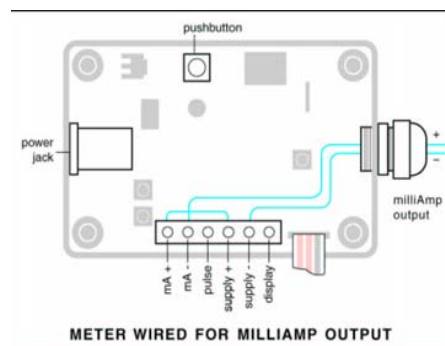

the mA- terminal to the positive side of the external receiver and from the negative side of the external receiver to the supply- terminal. Note that the supply- terminal is connected to the aluminum rings, and thus is normally connected to the pipe on which the meter is mounted.

### PULSE OUTPUT

The pulse output is an open-drain output, that is, a transistor switch connected to the meter's negative supply. To use the output, connect it to an input of the receiving device (usually a counter or PLC) and connect a pullup resistor from that input to a positive supply suitable for the receiving device. Also connect the negative supply terminal of the meter to the negative supply of the receiving device.

### SERIAL COMMUNICATION OPTION

The RS-485 signal used with the Serial Communication option is wired to the special Serial Communication display board. The two threaded openings in the meter enclosure permit the signal to be wired from meter to meter without external splices. Please refer to the data sheet for the Serial Communication option.

## Using the Outputs

The milliamp output is scaled so that four milliamps corresponds to zero flow and 20 milliamps corresponds to a flow rate that is above the calibrated range. There are two ways to determine the flow rate corresponding to 20 milliamps for a particular meter. The first is to look at the sticker inside the meter; it gives both the calibrated full-scale flow and the milliamp range. The second way is to press the button on the main circuit board twice. On the first press, the display will indicate zero and the meter will put out four milliamps; and on the second press the display will indicate the full-scale value and the meter will put out 20 milliamps.

The pulse output generates a square wave signal, sending five pulses for each cubic foot of air that passes through the meter.

## Maintenance

If oil or dirt accumulates on the probes, the meter will read low. For this reason, we recommend cleaning the probes from time to time. To clean the probes, wipe them with a cloth dampened with alcohol or a similar degreaser. It may be found that the system is clean enough that cleaning is not needed.